



Gas Furnaces 95AF

PRODUCT SPECIFICATIONS

INSTALLATION OPTIONS

- Available in Upflow/Horizontal and Counterflow models

HEAT EXCHANGER

- Aluminized steel tapered design primary heat exchanger with crimped construction for long life
- Stainless steel secondary heat exchanger
- Flue Condensate Trap furnished

BURNERS

- Aluminized steel inshot burners for smooth combustion

CABINET CONSTRUCTION

- Unitized construction for cabinet integrity
- Bottom or side return air
- Baked on pre-painted steel cabinet finish
- Left or right side gas and electric entry

BLOWER

- Easily removable slide-out blower design
- PSC multi-speed permanently lubricated blower motor for low maintenance and optimum efficiency

CONTROLS

- Single stage gas valve
- Integrated ignition and fan control board features self diagnostics
- Hot surface ignitor

VENTING

- One or two pipe venting ready

95% AFUE
44,000 to 110,000 Btuh Input
2 to 5 Tons Add-On Cooling



Upflow /
Horizontal



Counterflow

Warranty
Heat Exchanger - 20 Year Limited
Parts - 5 Year Limited

Gas Furnaces

95AF

Model Number Identification

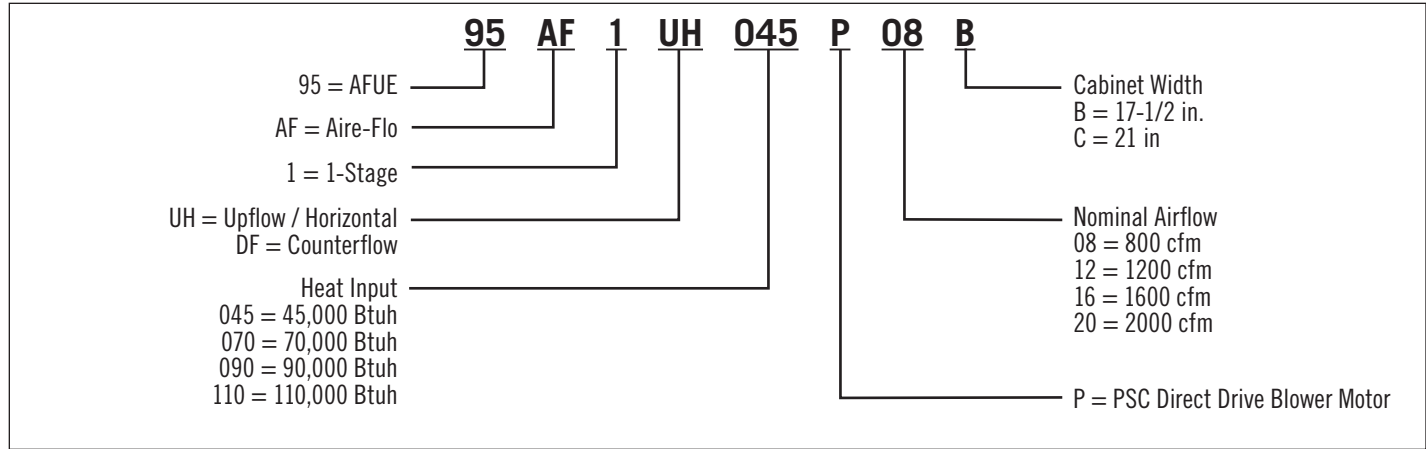

Specifications

Model No.	95AF1UH045P08B	95AF1UH070P12B	95AF1UH090P12C	95AF1UH090P16C	95AF1UH110P20C
	Upflow / Horiz.	Upflow / Horiz.	Upflow / Horiz.	Upflow / Horiz.	Upflow / Horiz.
Input Btuh	44,000	66,000	88,000	88,000	110,000
Output Btuh	41,000	64,000	85,000	85,000	106,000
AFUE (Isolated Comb. System)	95.0%	95.0%	95.0%	95.0%	95.0%
Temperature Rise (°F)	40 - 70	40 - 70	50 - 80	40 - 70	40 - 70
Gas Pipe Size (in.)	1/2	1/2	1/2	1/2	1/2
Inlet/Vent Connection in. (diameter)	2	2	2	2	2
Condensate Drain Trap (PVC) - i.d.	3/4	3/4	3/4	3/4	3/4
Volts/Hertz/Phase	120/60/1	120/60/1	120/60/1	120/60/1	120/60/1
Blower Motor Horsepower	1/5	1/3	1/3	1/2	1
Add-On Cooling (tons)	2-2.5	2-3	2-3	3-4	4-5
Circuit Breaker or Fuse	12	12	12	12	15
Full Load Amps	3.1	6.1	6.1	8.2	11.5
Blower Wheel Size (Dia. x Width)	10 x 8	10 x 8	10 x 8	10 x 10	11 1/2 x 10
Shipping Weight (lbs.)	119	129	144	154	164

Model No.	95AF1DF045P12B	95AF1DF070P12B	95AF1DF090P20C
	Counterflow	Counterflow	Counterflow
Input Btuh	44,000	66,000	88,000
Output Btuh	43,000	64,000	86,000
AFUE (Isolated Comb. System)	95.0%	95.0%	95.0%
Temperature Rise (°F)	25 - 55	50 - 80	40 - 70
Gas Pipe Size (in.)	1/2	1/2	1/2
Inlet/Vent Connection in. (diameter)	2	2	2
Condensate Drain Trap (PVC) - i.d.	3/4	3/4	3/4
Volts/Hertz/Phase	120/60/1	120/60/1	120/60/1
Blower Motor Horsepower	1/3	1/3	1/2
Add-On Cooling (tons)	3	3	4
Circuit Breaker or Fuse	15	15	15
Full Load Amps	6.1	6.1	8.2
Blower Wheel Size (Dia. x Width)	10 x 8	10 x 8	10 x 10
Shipping Weight (lbs.)	121	134	154

Gas Furnaces

95AF

Accessories

Model No.		95AF1UH045P08B 95AF1UH070P12B	95AF1UH090P12C 95AF1UH090P16C 95AF1UH110P20C	95AF1DF045P12B 95AF1DF070P12B	95AF1DF090P20C	
		Upflow / Horiz.	Upflow / Horiz.	Counterflow	Counterflow	
CABINET						
Combustible Flooring Base (Counterflow)		---	---	11M60	11M61	
Horizontal Suspension Kit (Horizontal)		51W10	51W10	---	---	
Return Air Base (Upflow)		50W98	50W99	---	---	
DRAIN KIT						
Condensate Drain Heat Cable	6 ft.	26K68	26K68	26K68	26K68	
	24 ft.	26K69	26K69	26K69	26K69	
	50 ft.	26K70	26K70	26K70	26K70	
Heat Cable Tape	Fiberglass ½ in. x 66 ft.	36G53	36G53	36G53	36G53	
	Alum. Foil 2 in. x 60 ft.	16P89	16P89	16P89	16P89	
Crawlspace Vent Drain Kit		51W18	51W18	51W18	51W18	
FILTER KITS						
¹ Air Filter and Rack Kit (Upflow/ Horizontal)	Horizontal (end)	87L96 (18 x 25 x 1)	87L97 (20 x 25 x 1)	---	---	
	Side Return (Upflow)	Single	44J22	44J22	---	---
		10-pack	66K63	66K63	---	---
		Size	16 x 25 x 1	16 x 25 x 1	---	---
¹ Air Filter and Rack Kit (Counterflow)		---	---	51W07 (2) 20 x 20 x 1	51W08 (2) 20 x 20 x 1	
GAS HEATING						
Natural to LP Conversion Kit		0-7500 ft.	69W73	69W73	69W73	
LP to Natural Conversion Kit		0-7500 ft.	73W81	73W81	73W81	
High Altitude Pressure Switch Kit	4501-7500 ft.	No change (045) 93W93 (070)	93W92 (090) 93W93 (110)	No change (045) 93W93 (070)	93W92 (090)	
	7501-10,000 ft.	93W87 (045) 93W86 (070)	93W86	93W87 (045) 93W86 (070)	93W86	
Natural Gas High Altitude Orifice Kit		7501-10,000 ft.	73W37	73W37	73W37	
LP High Altitude Orifice Kit		7501-10,000 ft.	68W68	68W68	68W68	
² 36K Derate Kit (Natural Gas)		0-10,000 ft.	10K55 (045)	---	10K55 (045)	
NIGHT SERVICE KIT						
Night Service Kit		68W80	68W80	68W80	68W80	
VENTING						
Concentric Vent Kit	2 in. (US)	71M80	69M29	71M80	69M29	
	3 in. (US)	---	60L46	---	60L46	
	2 in. (Canada)	44W92	44W92	44W92	44W92	
	3 in. (Canada)	---	44W93	---	44W93	
Flush Mount	2, 2-1/2 or 3 in. (US)	51W11	51W11	51W11	51W11	
	2, 2-1/2 or 3 in. (Canada)	51W12	51W12	51W12	51W12	
Wall - Close Couple	2 in. (US)	22G44	---	22G44	---	
	3 in. (US)	44J40	44J40	44J40	44J40	
Wall - Close Couple WTK	2 in. (Canada)	30G28	---	30G28	---	
	3 in. (Canada)	81J20	81J20	81J20	81J20	
Roof	2 in.	15F75	15F75	15F75	15F75	
Wall Ring Kit	2 in.	15F74	³ 15F74	15F74	³ 15F74	
³ Flashing Kit	2 in.	44J41	44J41	44J41	44J41	

¹ Cleanable polyurethane frame type filter.

² NOTE - 36K Derate Kit information - Reduced Input is 36,000 Btuh, output is 34,200 Btuh.

³ Kits contain enough parts for two, non-direct vent installations.

⁴ Non-direct vent only.

NOTE - Termination Kits 44W92, 44W93, 30G28, 51W12, 81J20 are certified to ULC S636 standard for use in Canada only.

Gas Furnaces

95AF

Blower Data

Model No.	Blower Speed	¹ CFM @ External Static Pressure - in w.c. Less Filter									
		.00	.10	.20	.30	.40	.50	.60	.70	.80	.90
95AF1UH045P08B (Upflow / Horizontal)	High	1140	1135	1125	1090	1065	1020	945	910	790	735
	Med/High	920	900	895	870	870	825	780	740	670	575
	Med/Low	765	765	755	725	715	675	640	585	510	460
	Low	710	690	680	660	635	605	555	505	455	390
95AF1UH070P12B (Upflow / Horizontal)	High	1585	1560	1515	1465	1410	1345	1275	1195	1105	985
	Med/High	1340	1320	1300	1275	1235	1195	1140	1090	995	890
	Med/Low	1095	1085	1080	1065	1050	1020	975	930	850	770
	Low	880	885	880	890	875	840	830	780	730	650
95AF1UH090P12C (Upflow / Horizontal)	High	1630	1615	1580	1525	1480	1415	1350	1260	1190	1060
	Med/High	1345	1320	1305	1295	1275	1220	1175	1115	1010	930
	Med/Low	1090	1070	1070	1060	1055	1030	1005	955	880	795
	Low	885	890	890	890	885	860	835	785	740	655
95AF1UH090P16C (Upflow / Horizontal)	High	2140	2110	2060	1990	1925	1830	1720	1600	1455	1300
	Med/High	1895	1880	1835	1805	1755	1680	1610	1525	1410	1305
	Med/Low	1590	1585	1580	1550	1510	1455	1390	1300	1195	1100
	Low	1350	1360	1360	1365	1330	1285	1230	1165	1035	900
95AF1UH110P20C (Upflow / Horizontal) Single Side Return Air - Air volumes in bold require field fabricated transition to accommodate 20 x 25 x 1 in. air filter in order to maintain proper air velocity.	High	2400	2370	2320	2235	2165	2040	1960	1865	1715	1630
	Med/High	2100	2090	2060	2040	1975	1920	1845	1750	1590	1490
	Med/Low	1755	1735	1720	1725	1700	1700	1635	1575	1505	1460
	Low	1320	1330	1340	1350	1330	1325	1340	1295	1280	1235
Bottom Return Air, Side Return Air with Optional Return Air Base, Return Air from Both Sides or Return Air from Bottom and One Side.	High	2485	2460	2405	2335	2215	2185	2060	1945	1845	1730
	Med/High	2090	2075	2040	1990	1935	1865	1805	1700	1605	1570
	Med/Low	1835	1810	1790	1760	1740	1680	1630	1605	1505	1470
	Low	1380	1390	1405	1460	1410	1410	1405	1380	1305	1250
95AF1DF045P12B (Counterflow)	High	1615	1605	1500	1450	1350	1300	1195	1140	1025	945
	Med/High	1385	1380	1345	1290	1235	1170	1095	1020	920	800
	Med/Low	1205	1195	1165	1125	1090	1035	990	895	840	700
	Low	1045	1035	1015	975	920	880	840	780	695	605
95AF1DF070P12B (Counterflow)	High	1515	1490	1445	1380	1315	1270	1155	1075	975	900
	Med/High	1315	1300	1275	1240	1190	1145	1075	1000	900	800
	Med/Low	1095	1075	1065	1060	1020	995	940	875	800	675
	Low	910	890	910	900	875	870	820	765	715	615
95AF1DF090P20C (Counterflow)	High	2305	2295	2200	2160	2055	1970	1890	1775	1690	1580
	Med/High	2145	2135	2085	1990	1935	1855	1765	1680	1590	1485
	Med/Low	1900	1885	1865	1830	1790	1705	1635	1565	1485	1405
	Low	1515	1500	1525	1545	1530	1500	1495	1430	1370	1270

Notes:

¹ Maximum approved external static pressure is 0.50 in. w.c.

Gas Furnaces 95AF

Clearance to Combustibles (in.)

Sides	¹ 0
Rear	0
Top/Plenum	1
Front	0
Front (service/alcove)	24
Floor	² Combustible

NOTE – Air for combustion must conform to the methods outlined in the National Fuel Gas Code (NFPA 54/ANSI-Z223.1) or the National Standard of Canada CAN/CSA-B149.1 Natural Gas and Propane Installation Code”.

NOTE – In the U.S. flue sizing must conform to the methods outlined in the current National Fuel Gas Code (NFPA 54/ANSI-Z223.1) or applicable provisions of local building codes. In Canada flue sizing must conform to the methods outlined in National Standard of Canada CAN/CSA-B149.1.

¹ Allow proper clearances to accommodate condensate trap and vent pipe installation.

² Do not install the furnace directly on carpeting, tile, or other combustible materials other than wood flooring.

Gas Furnaces 95AF

Vent Lengths - Feet - Upflow / Horizontal

NOTE - Size intake and exhaust pipe length separately. Values in table are for Intake OR Exhaust, not combined total. Both Intake and Exhaust must be same pipe size.

STANDARD TERMINATION AT ELEVATION 0 - 4500 ft.													
Pipe Size		2 in.				2-1/2 in.				3 in.			
Input		045	070	090	110	045	070	090	110	045	070	090	110
No. of 90° elbows used	1	76	61	39	19	110	95	63	38	132	132	113	113
	2	71	56	34	14	105	90	58	33	127	127	108	108
	3	66	51	29	N/A	100	85	53	28	122	122	103	103
	4	61	46	24	N/A	95	80	48	23	117	117	98	98
	5	56	41	19	N/A	90	75	43	18	112	112	93	93
	6	51	36	14	N/A	85	70	38	13	107	107	88	88
	7	46	31	N/A	N/A	80	65	33	N/A	102	102	83	83
	8	41	26	N/A	N/A	75	60	28	N/A	97	97	78	78
	9	36	21	N/A	N/A	70	55	23	N/A	92	92	73	73
	10	31	16	N/A	N/A	65	50	18	N/A	87	87	68	68
STANDARD TERMINATION AT ELEVATION 4501 - 10,00 ft.													
Pipe Size		2 in.				2-1/2 in.				3 in.			
Input		045	070	090	110	045	070	090	110	045	070	090	110
No. of 90° elbows used	1	76	61	39	N/A	110	95	63	38	132	132	113	113
	2	71	56	34	N/A	105	90	58	33	127	127	108	108
	3	66	51	29	N/A	100	85	53	28	122	122	103	103
	4	61	46	24	N/A	95	80	48	23	117	117	98	98
	5	56	41	19	N/A	90	75	43	18	112	112	93	93
	6	51	36	14	N/A	85	70	38	13	107	107	88	88
	7	46	31	N/A	N/A	80	65	33	N/A	102	102	83	83
	8	41	26	N/A	N/A	75	60	28	N/A	97	97	78	78
	9	36	21	N/A	N/A	70	55	23	N/A	92	92	73	73
	10	31	16	N/A	N/A	65	50	18	N/A	87	87	68	68
CONCENTRIC TERMINATION ELEVATION 0 - 4500 ft.													
Pipe Size		2 in.				2-1/2 in.				3 in.			
Input		045	070	090	110	045	070	090	110	045	070	090	110
No. of 90° elbows used	1	68	53	37	17	100	85	59	34	116	116	109	109
	2	63	48	32	12	95	80	54	29	111	111	104	104
	3	58	43	27	N/A	90	75	49	24	106	106	99	99
	4	53	38	22	N/A	85	70	44	19	101	101	94	94
	5	48	33	17	N/A	80	65	39	14	96	96	89	89
	6	43	28	12	N/A	75	60	34	N/A	91	91	84	84
	7	38	23	N/A	N/A	70	55	29	N/A	86	86	79	79
	8	33	18	N/A	N/A	65	50	24	N/A	81	81	74	74
	9	28	13	N/A	N/A	60	45	19	N/A	76	76	69	69
	10	23	N/A	N/A	N/A	55	40	14	N/A	71	71	64	64
CONCENTRIC TERMINATION ELEVATION 4500 - 10,000 ft.													
Pipe Size		2 in.				2-1/2 in.				3 in.			
Input		045	070	090	110	045	070	090	110	045	070	090	110
No. of 90° elbows used	1	68	53	37	N/A	100	85	59	34	116	116	109	109
	2	63	48	32	N/A	95	80	54	29	111	111	104	104
	3	58	43	27	N/A	90	75	49	24	106	106	99	99
	4	53	38	22	N/A	85	70	44	19	101	101	94	94
	5	48	33	17	N/A	80	65	39	14	96	96	89	89
	6	43	28	12	N/A	75	60	34	N/A	91	91	84	84
	7	38	23	N/A	N/A	70	55	29	N/A	86	86	79	79
	8	33	18	N/A	N/A	65	50	24	N/A	81	81	74	74
	9	28	13	N/A	N/A	60	45	19	N/A	76	76	69	69
	10	23	N/A	N/A	N/A	55	40	14	N/A	71	71	64	64

Gas Furnaces 95AF

Vent Lengths - Feet - Counterflow

NOTE - Size intake and exhaust pipe length separately. Values in table are for Intake OR Exhaust, not combined total. Both Intake and Exhaust must be same pipe size.

STANDARD TERMINATION AT ELEVATION 0 - 10,000 ft.													
Pipe Size		2 in.				2-1/2 in.				3 in.			
Input		045	070	090	110	045	070	090	110	045	070	090	110
No. of 90° elbows used	1	56	41	19	N/A	95	75	38	N/A	122	122	103	103
	2	51	36	14	N/A	90	70	33	N/A	117	117	98	98
	3	46	31	N/A	N/A	85	65	28	N/A	112	112	93	93
	4	41	26	N/A	N/A	80	60	23	N/A	107	107	88	88
	5	36	21	N/A	N/A	75	55	18	N/A	102	102	83	83
	6	31	16	N/A	N/A	70	50	13	N/A	97	97	78	78
	7	26	11	N/A	N/A	65	45	N/A	N/A	92	92	73	73
	8	21	N/A	N/A	N/A	60	40	N/A	N/A	87	87	68	68
	9	16	N/A	N/A	N/A	55	35	N/A	N/A	82	82	63	63
	10	11	N/A	N/A	N/A	50	30	N/A	N/A	77	77	58	58
CONCENTRIC TERMINATION ELEVATION 0 - 10,000 ft.													
Pipe Size		2 in.				2-1/2 in.				3 in.			
Input		045	070	090	110	045	070	090	110	045	070	090	110
No. of 90° elbows used	1	48	33	17	N/A	85	65	34	N/A	106	106	99	99
	2	43	28	12	N/A	80	60	29	N/A	101	101	94	94
	3	38	23	N/A	N/A	75	55	24	N/A	96	96	89	89
	4	33	18	N/A	N/A	70	50	19	N/A	91	91	84	84
	5	28	13	N/A	N/A	65	45	14	N/A	86	86	79	79
	6	23	N/A	N/A	N/A	60	40	N/A	N/A	81	81	74	74
	7	18	N/A	N/A	N/A	55	35	N/A	N/A	76	76	69	69
	8	13	N/A	N/A	N/A	50	30	N/A	N/A	71	71	64	64
	9	N/A	N/A	N/A	N/A	45	25	N/A	N/A	66	66	59	59
	10	N/A	N/A	N/A	N/A	40	20	N/A	N/A	61	61	54	54

Gas Furnaces 95AF

Dimensions - inches (mm) Upflow

¹ NOTE - 20C size units that require air volumes over 1800 cfm must have one of the following:

1. Single side return air with transition, to accommodate 20 x 25 x 1 in. cleanable air filter. Required to maintain proper air velocity.
 2. Single side return air with Optional Return Air Base
 3. Bottom return air.
 4. Return air from both sides.
 5. Bottom and one side return air.
- See Blower Performance Tables for additional information.

² Optional Side Return Air Filter Kit is not for use with the Optional Return Air Base.

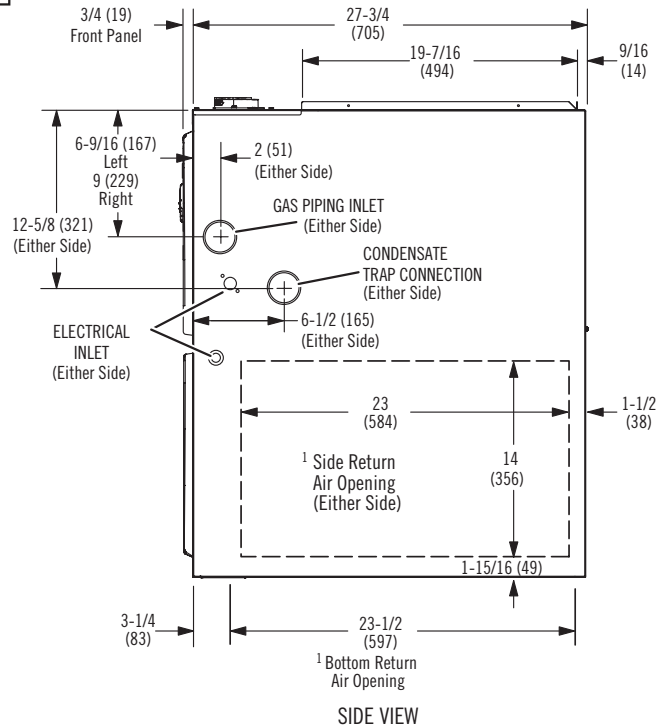
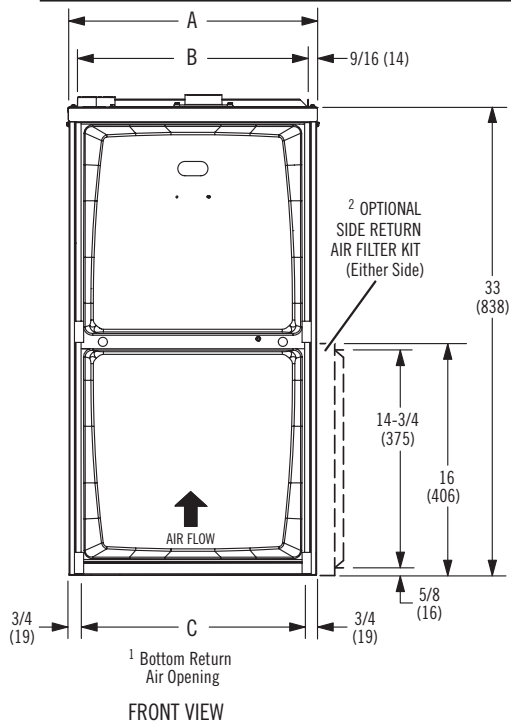
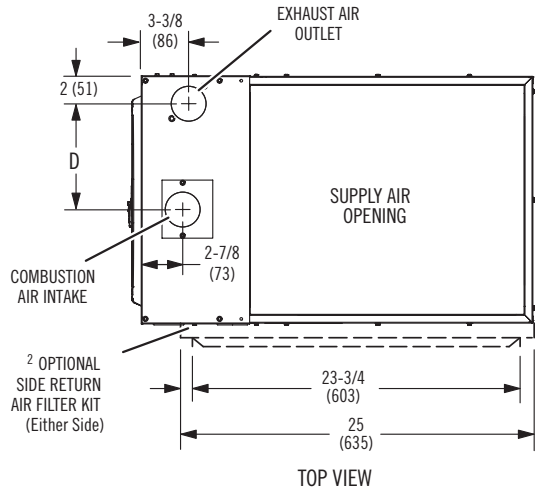
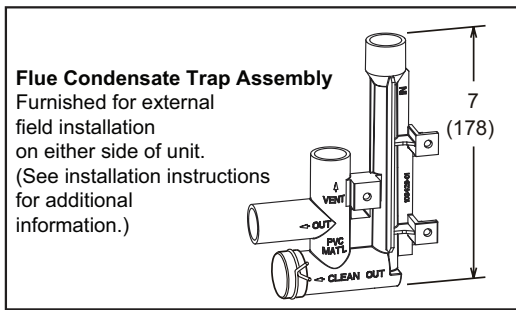

Model No.	A		B		C		D	
	in.	mm	in.	mm	in.	mm	in.	mm
95AF1UH045P08B 95AF1UH070P12B	17-1/2	446	16-3/8	416	16	406	7-5/8	194
95AF1UH090P12C 95AF1UH090P16C 95AF1UH110P20C	21	533	19-7/8	505	19-1/2	495	9-3/8	238

Gas Furnaces 95AF

Dimensions - inches (mm) Horizontal

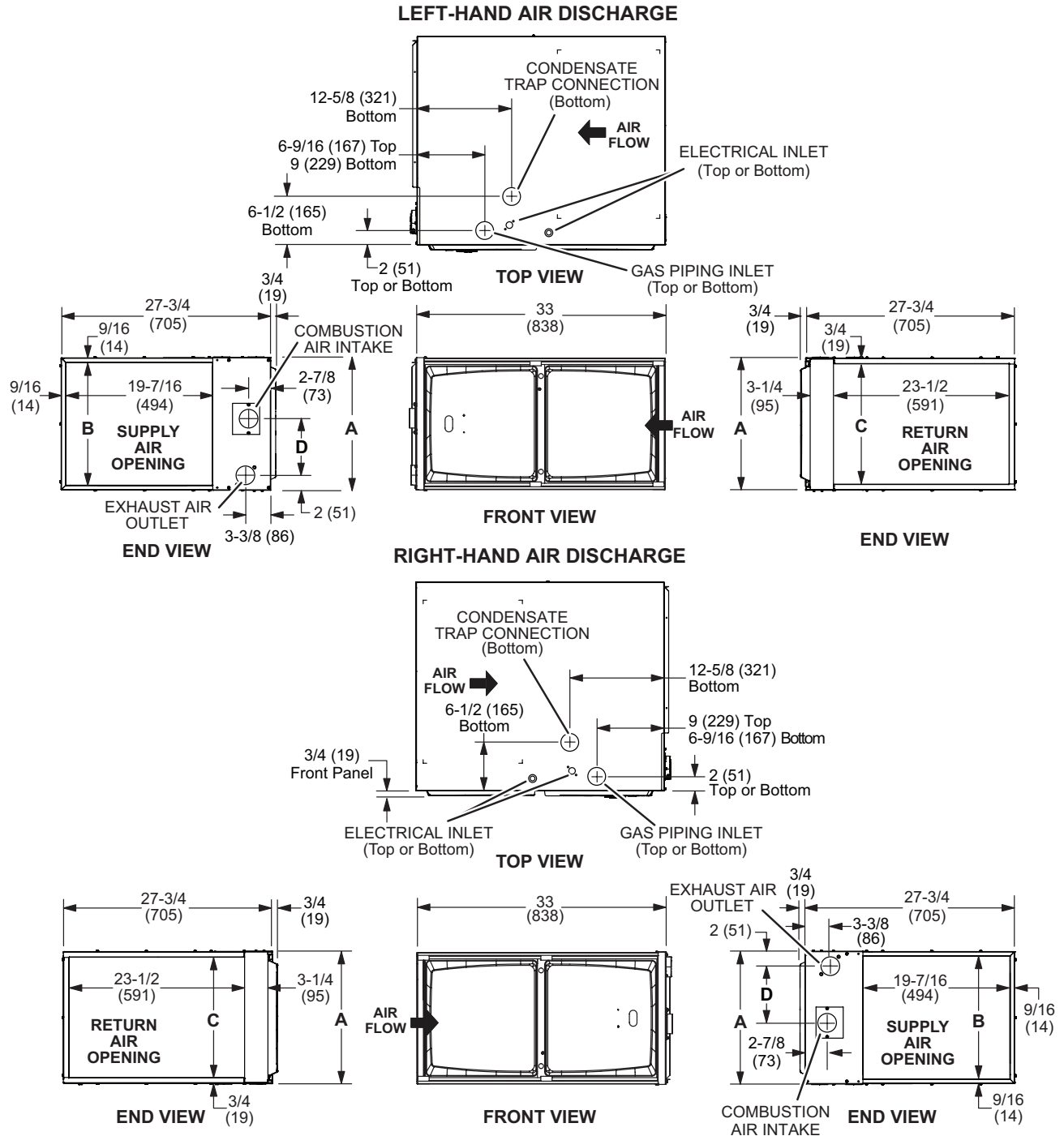

Model No.	A		B		C		D	
	in.	mm	in.	mm	in.	mm	in.	mm
95AF1UH045P08B 95AF1UH070P12B	17-1/2	446	16-3/8	416	16	406	7-5/8	194
95AF1UH090P12C 95AF1UH090P16C 95AF1UH110P20C	21	533	19-7/8	505	19-1/2	495	9-3/8	238

Gas Furnaces 95AF

Dimensions - in. (mm) Counterflow

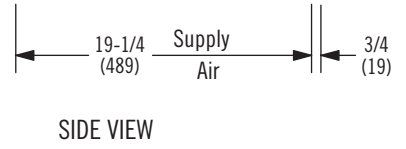
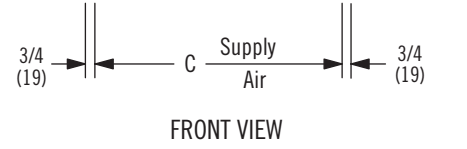
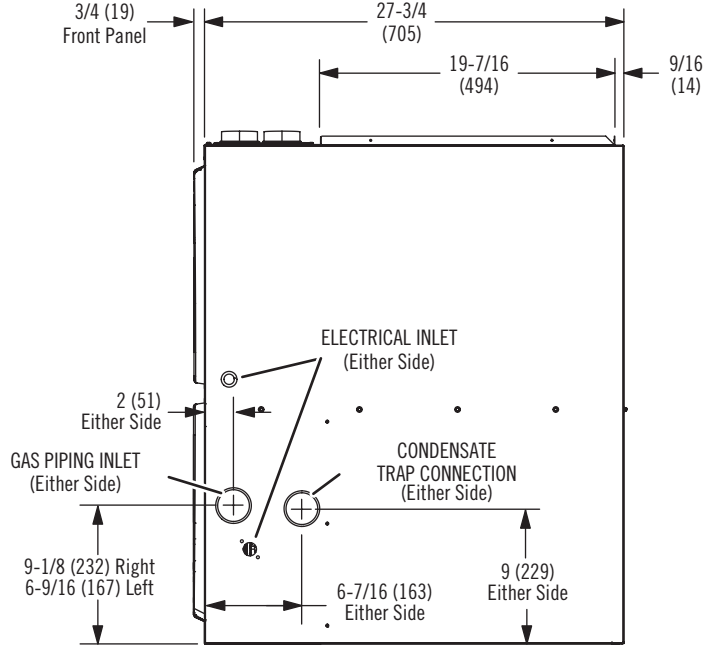
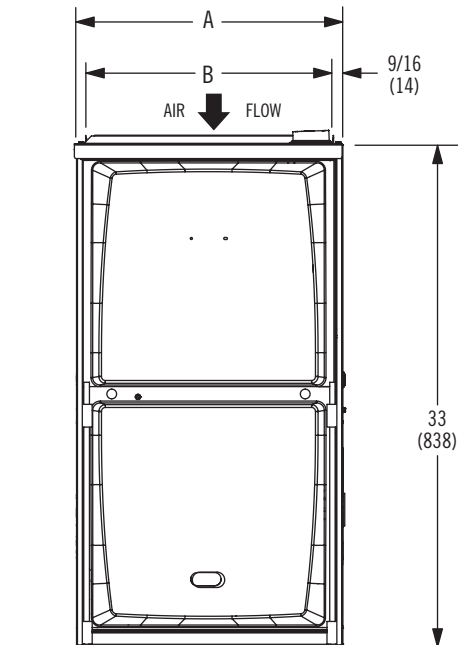
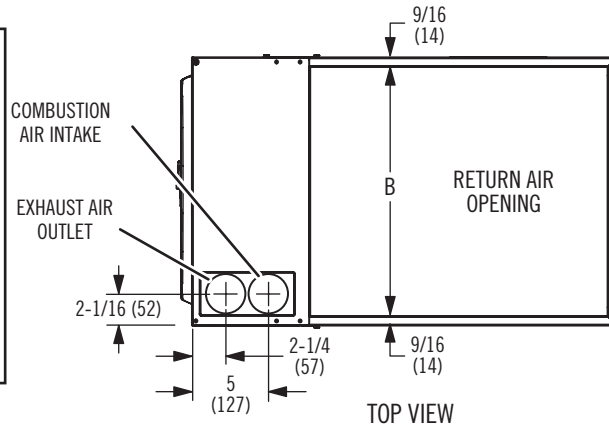
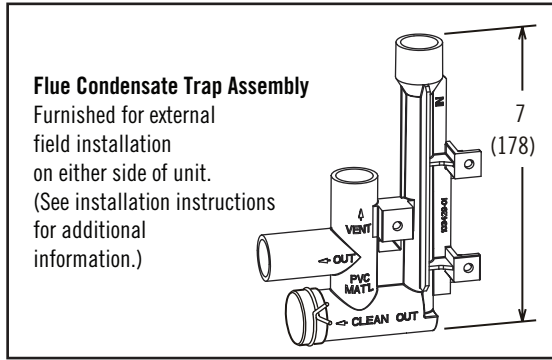

Model No.	A		B		C	
	in.	mm	in.	mm	in.	mm
95AF1DF045P12B 95AF1DF070P12B	17-1/2	446	16-3/8	416	16	406
95AF1DF090P20C	21	533	19-7/8	505	19-1/2	495

Gas Furnaces

95AF

Revisions

Sections	Description of Change
Accessories/Gas Heating	Added 36K Derate Kit.



1.800.982.2333
www.aireflo-hvac.com



210598 (05/13)

© Aire-Flo Heating and Cooling, 2013